

1" GAS VALVE



711-7100-1-GHP

Pressure: 15-2000#

Volume: to 3332 CFM

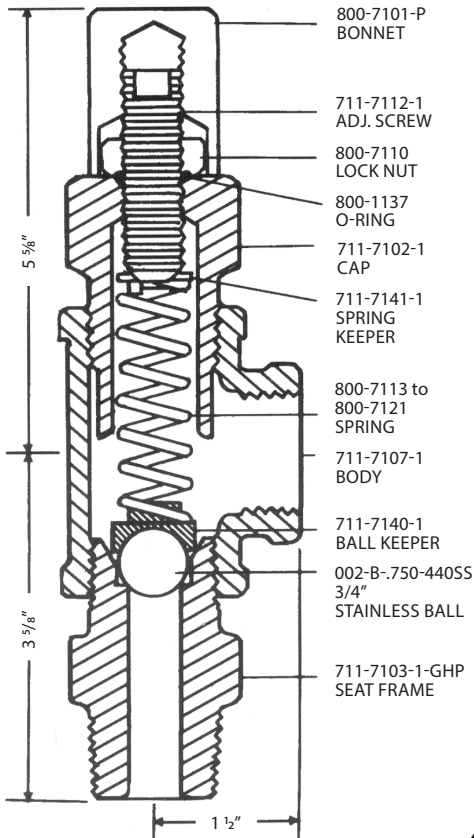

INLETS AVAILABLE: Male NPT 1", 3/4"

OUTLET: Female NPT 1"

INLET ADAPTORS AVAILABLE: Female NPT 1", 3/4", 1/2"

TEMPERATURE RANGE: -65° to +300° F

BODY: (Specify)
 FORGED STEEL — Standard
 316 STAINLESS — Add "316" to Model #

TRIM: Stainless Steel

MANUAL RELEASE LEVER: Optional — Add "H" to Model #

APPLICATION: Recommended for overpressure protection on separators, compressor tanks, heater-treaters, meter runs, gathering lines, transmission systems, gas manifolds, refinery service and other gas systems.

FIELD REPAIRS AND ADJUSTMENTS ARE EASILY MADE ON-SITE, REQUIRING NO SPECIAL TOOLS OR EQUIPMENT.



RELIEVING CAPACITIES: 3/8" ORIFICE = .110 SQ. IN., 90% SLOPE = .15

FORGED STEEL VALVE PART NUMBER	WORKING PRESSURE RANGE	CFM OF AIR AT MAXIMUM SETTING +10%
711-7100-1-GHP-50	25 - 50#	50# = 104 CFM
711-7100-1-GHP-100	50 - 100#	100# = 187 CFM
711-7100-1-GHP-225	100 - 225#	225# = 393 CFM
711-7100-1-GHP-350	225 - 350#	350# = 599 CFM
711-7100-1-GHP-600	350 - 600#	600# = 1012 CFM
711-7100-1-GHP-800	600 - 800#	800# = 1342 CFM
711-7100-1-GHP-1100	800 - 1100#	1100# = 1837 CFM
711-7100-1-GHP-1300	1100 - 1300#	1300# = 2167 CFM
711-7100-1-GHP-2000	1300 - 2000#	2000# = 3322 CFM

